



1100 Series Card Edge Connector .100" X .200" Contact Spacing

Specifications

Insulator Material: Glass filled polyester, type PBT,
94 V-O, UL Rated.

Contact Material: Phosphor Bronze Alloy

Contact Plating: Gold and/or Tin over .000050" Nickel,
(See Contact Plating Options).

Current Rating: 3 amp at 30°C

Contact Resistance:
Contact to Daughter Card:
10 m max.

Insulation Resistance:
5000 M min.

Dielectric Withstand Voltage:
1000 V AC

Daughter Board Insertion Force:
16 oz max. per contact pair
when tested with a .071" thick
gage.

Daughter Board Withdrawal Force:
1 oz min. per contact pair
when tested with a .054" thick
gage.

Operating Temperature:
-54°C to +125°C

Features

- Extra large chamfered entry
- Conforms to Bell-core spec TR-TSY-00078
- Extended card scoops available
- Replaceable contacts
- Molded in polarization available between contact, or on contact position.
- De-population of contacts per customer specification.
- Available in selective gold plate at contact point
- Many other custom options available, including, but not limited to:
 - Single or Both Ends Open
 - Shorting Contacts



Recognized under the recognized component Program of Underwriters Laboratories, Inc.
File Numbers: E146967 and E176234

POS. / CONTACTS	A	B	C
05/10	0.756 [19.20]	0.600 [15.24]	0.400 [10.16]
10/20	1.256 [31.90]	1.100 [27.94]	0.900 [22.86]
12/24	1.456 [36.98]	1.300 [33.02]	1.100 [27.94]
15/30	1.756 [44.60]	1.600 [40.64]	1.400 [35.56]
18/36	2.056 [52.22]	1.900 [48.26]	1.700 [43.18]
20/40	2.256 [57.30]	2.100 [53.34]	1.900 [48.26]
22/44	2.456 [62.38]	2.300 [58.42]	2.100 [53.34]
25/50	2.756 [70.00]	2.600 [66.04]	2.400 [60.96]
28/56	3.056 [76.62]	2.900 [73.66]	2.700 [68.58]
30/60	3.256 [82.70]	3.100 [78.74]	2.900 [73.66]
31/62	3.356 [85.24]	3.200 [81.28]	3.000 [76.20]
35/70	3.756 [95.40]	3.600 [91.44]	3.400 [86.36]
36/72	3.856 [97.94]	3.700 [93.98]	3.500 [88.90]
40/80	4.256 [108.10]	4.100 [104.14]	3.900 [99.06]
43/86	4.556 [115.72]	4.400 [111.76]	4.200 [106.68]
50/100	5.256 [133.50]	5.100 [129.54]	4.900 [124.46]
55/110	5.756 [146.20]	5.600 [142.24]	5.400 [137.16]
60/120	6.256 [158.90]	6.100 [154.94]	5.900 [149.86]
65/130	6.756 [171.60]	6.600 [167.64]	6.400 [162.56]
70/140	7.256 [184.30]	7.100 [180.34]	6.900 [175.26]

For reference only, can go 1 through 70 positions.

Dimensions are in inch [mm]

MOUNTING STYLE

1 = Clearance Hole	2 = #4-40 Threaded Insert	3 = Flush Mount	4 = #4-40 Threaded Insert	5 = No Mounting Ear	6 = Side Mounting

.100" x .200" Contact Spacing

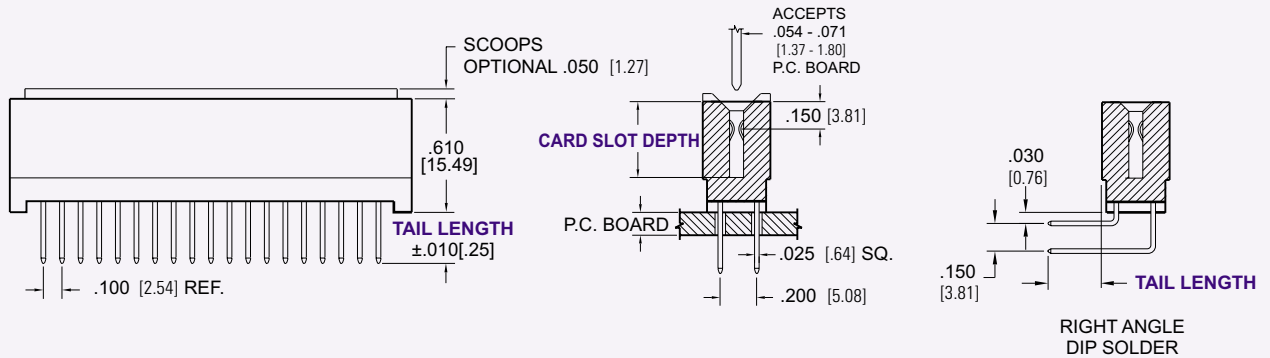
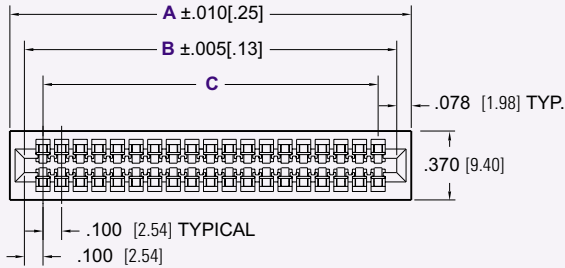
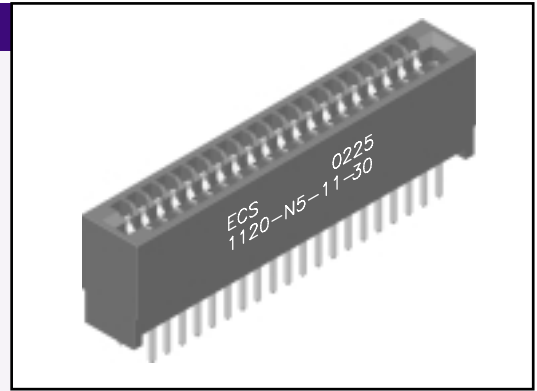

Dimensions are in inch [mm]

PART NUMBERING

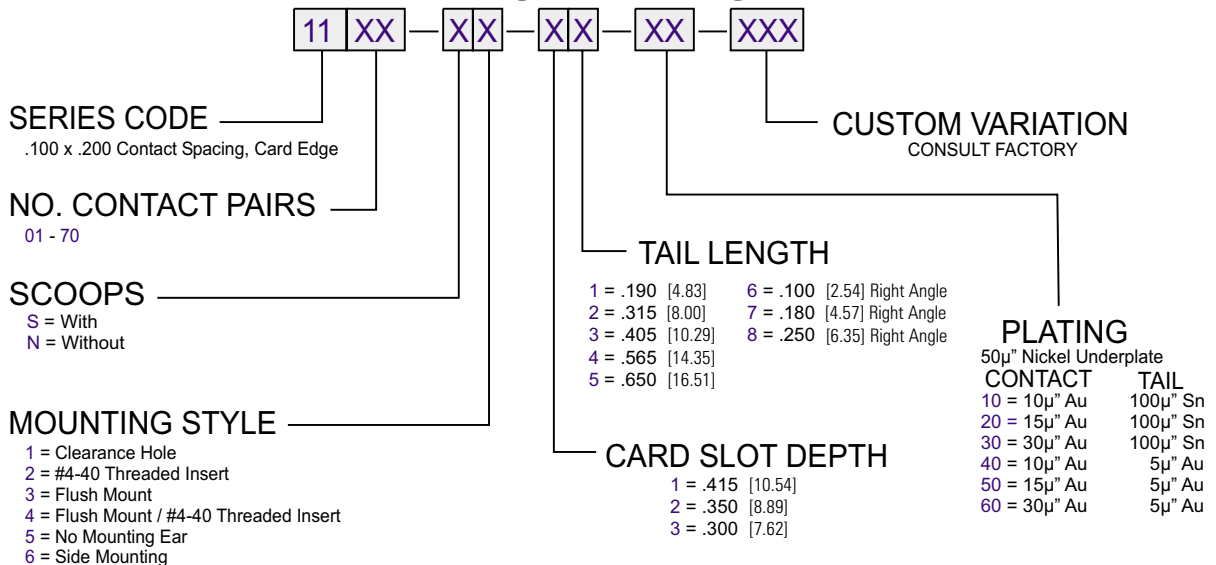

CONSULT FACTORY FOR CONNECTORS BUILT TO YOUR SPECIFICATION