



# 1800 Series Card Edge Connector

## .050[1.27] Contact Centers, Right Angle Termination

### Specifications

- Accommodates .062K.008 PC Board
- Ryton or Thermx insulator
- 1 amp current rating
- Insulation Resistance: 5000 M  $\Omega$
- Dielectric Withstand Voltage: 250 VDC
- Voltage Drop: 30 m volt at rated current
- Contact Resistance: 30 m  $\Omega$  max. at rated current
- Board Insertion Force: 16 oz. Max. per contact pair using .062 [1.58mm] thick steel test blade
- Board Withdrawal Force: 1 oz. Min. per contact pair using .062 [1.58mm] thick steel test blade.
- Operating Temperature: -54B to 125B C



Recognized under the recognized component Program of Underwriters Laboratories, Inc.  
File Numbers: E146967 and E176234

POS./CONTACTS	A	B	C	D	E
5/10	.200 [5.08]	.300 [7.62]	.490 [12.45]	.776 [19.71]	1.090 [27.69]
10/20	.450 [11.43]	.550 [13.97]	.740 [18.80]	1.026 [26.06]	1.340 [34.04]
15/30	.700 [17.78]	.800 [20.32]	.990 [25.15]	1.276 [32.41]	1.590 [40.39]
20/40	.950 [24.13]	1.050 [26.67]	1.240 [31.50]	1.526 [38.76]	1.840 [46.74]
25/50	1.200 [30.48]	1.300 [33.02]	1.490 [37.85]	1.776 [45.11]	2.090 [53.09]
30/60	1.450 [36.83]	1.550 [39.37]	1.740 [44.20]	2.026 [51.46]	2.340 [59.44]
35/70	1.700 [43.18]	1.800 [45.72]	1.990 [50.55]	2.276 [57.81]	2.590 [65.79]
40/80	1.950 [49.53]	2.050 [52.07]	2.240 [56.90]	2.526 [64.16]	2.840 [72.14]
45/90	2.200 [55.88]	2.300 [58.42]	2.490 [63.25]	2.776 [70.51]	3.090 [78.59]
50/100	2.450 [62.23]	2.550 [64.77]	2.740 [69.60]	3.026 [76.86]	3.340 [84.84]
55/110	2.700 [68.58]	2.800 [71.12]	2.990 [75.95]	3.276 [83.21]	3.590 [91.19]
60/120	2.950 [74.93]	3.050 [77.47]	3.240 [82.30]	3.526 [89.51]	3.840 [97.54]

Dimensions are in inch [mm]

### MOUNTING STYLE

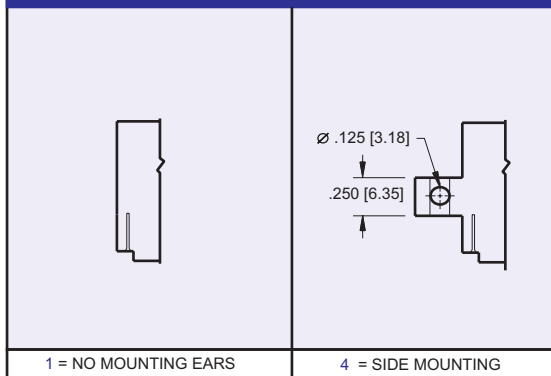

### TERMINATION TYPE

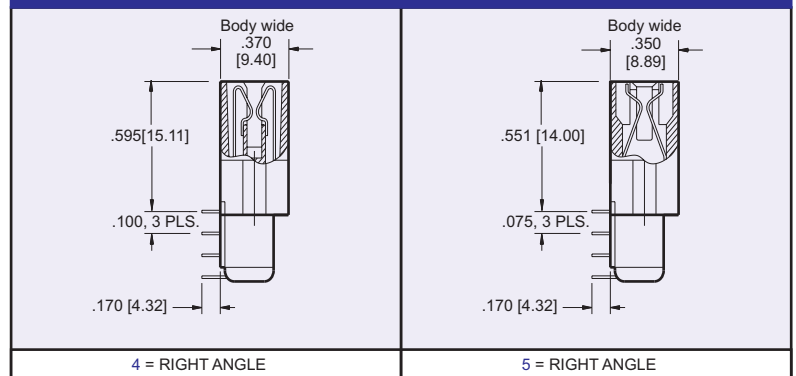

# .050 [1.27] Contact Centers, Right Angle

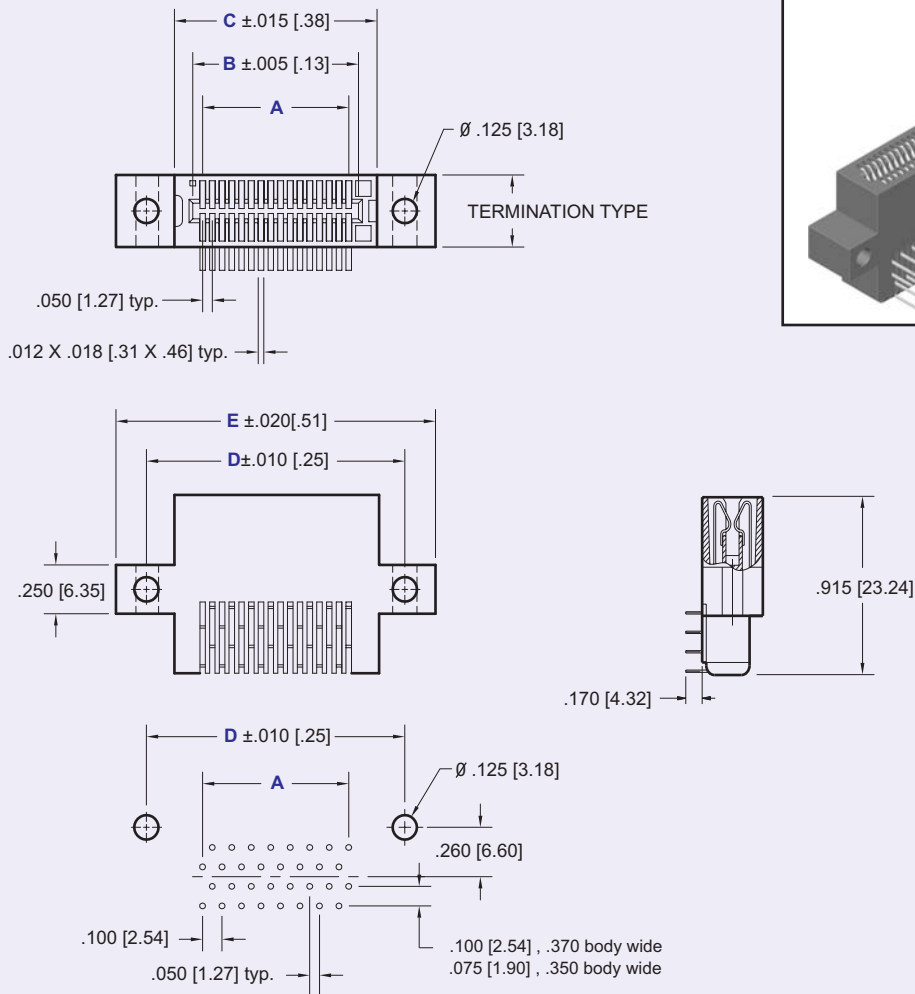
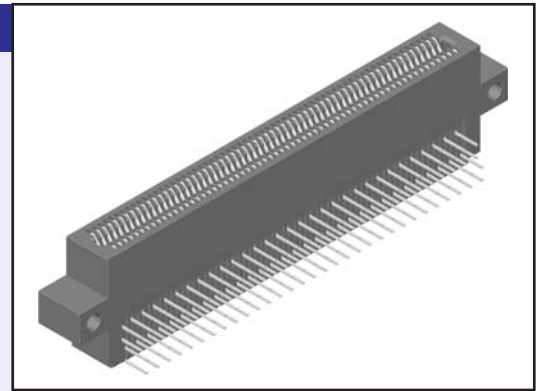

Dimensions are in inch [mm]

## PART NUMBERING

