

# 2.0mm FutureBus 4 Row Female Right Angle

Contact	Dim A	Dim B
24	11.95	10.00
48	23.95	22.00
72	35.95	34.00
96	47.95	46.00
120	59.95	58.00
144	71.95	70.00
168	83.95	82.00
192	95.95	94.00

## Specifications

1. Insulator Material: Liquid Crystal Polymer (LCP) 94V-O, UL Recognized.
2. Contact Material: Phosphor Bronze or Brass
3. Contact Plating: Gold and/or Tin over Nickel (see contact plating options)
4. Compliant Insertion Force: 22.1 lbs max. per contact
5. Compliant Withdrawal Force: 4.4 lbs min. per contact
6. Insulation Resistance: 1000 M ohms min. @ 500v
7. Contact Resistance: 30 m ohms max. @ DC 100mA
8. Dielectric Withstand Voltage: 1000 VAC for 1 min.
9. Current Rating: 1 Amp @ 20°C per contact
10. Operating Temperature: -55°C To +125°C
11. UL File Numbers: E 176234, IEEE 896.10 FutureBus+

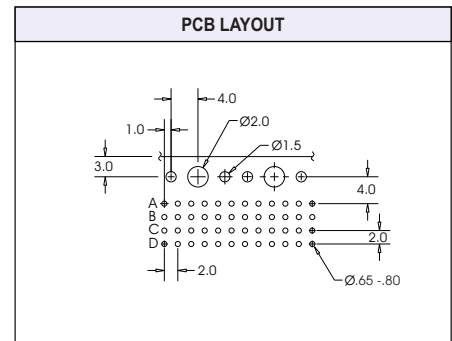
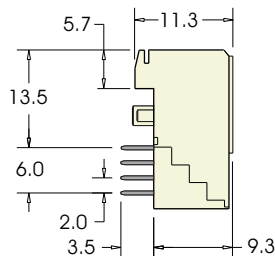
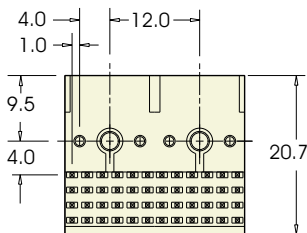
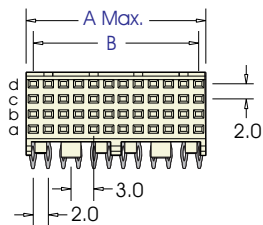
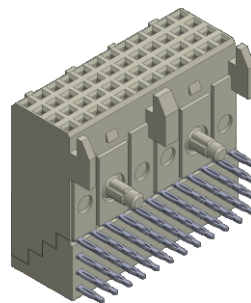

## PART NUMBERING

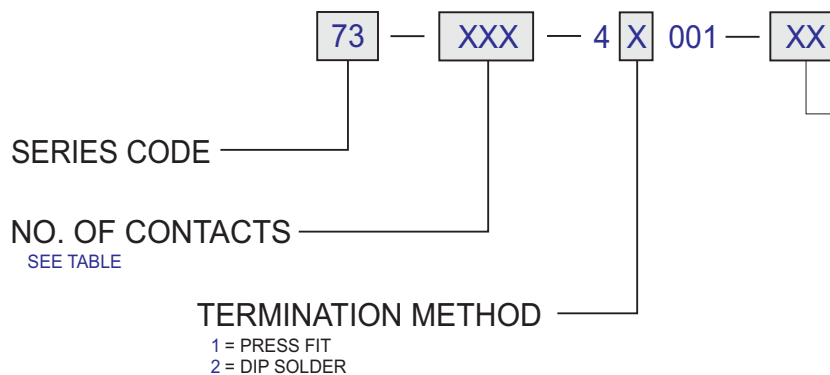

### CONTACT PLATING

.000050" Nickel underplate

CONTACT	TAIL
01 = Au Flash	100µ"Sn
10 = 10µ"Au	100µ"Sn
30 = 30µ"Au	100µ"Sn