

# 3 SNAPS CARD GUIDE F SERIES

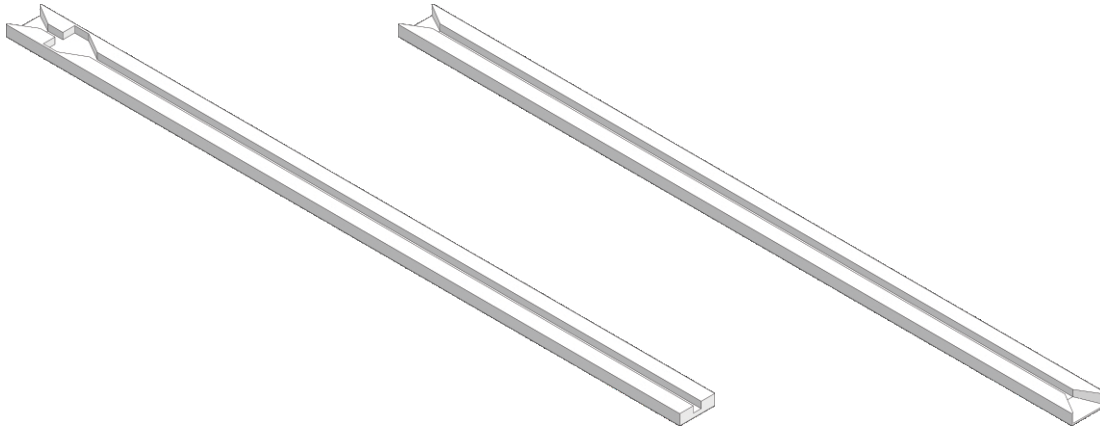

F series card guides are intended to snap into their support structure and are suitable for mounting in sheet metal or on to extrusions having a grip range of .050" to .090". This guide series is available in a range of lengths from 2 1/2" to 16".

Material: white, EMS A28GM, Natural



| PART NUMBER      | A               | B           | C           | D              | Dx2             | X           | Y           |
|------------------|-----------------|-------------|-------------|----------------|-----------------|-------------|-------------|
| <b>CG-1800F</b>  | 8.000 [203.20]  | .312 [7.92] | .125 [3.18] | 3.500 [88.90]  | 7.000 [177.8]   | .076 [1.93] | .075 [1.91] |
| <b>CG-1801F</b>  | 8.000 [203.20]  | .312 [7.92] | .175 [4.45] | 3.500 [88.90]  | 7.000 [177.8]   | .074 [1.88] | .125 [3.18] |
| <b>CG-1110F</b>  | 11.000 [279.40] | .312 [7.92] | .200 [5.08] | 5.000 [127.00] | 10.000 [254.00] | .077 [1.96] | .150 [3.81] |
| <b>CG-1110FS</b> | 11.000 [279.40] | .312 [7.92] | .150 [3.81] | 5.000 [127.00] | 10.000 [254.00] | .077 [1.96] | .100 [2.54] |



CG-1800F  
CG-1801F



CG-1110F  
CG-1110FS

