

# 4 Row HDI Female Vertical

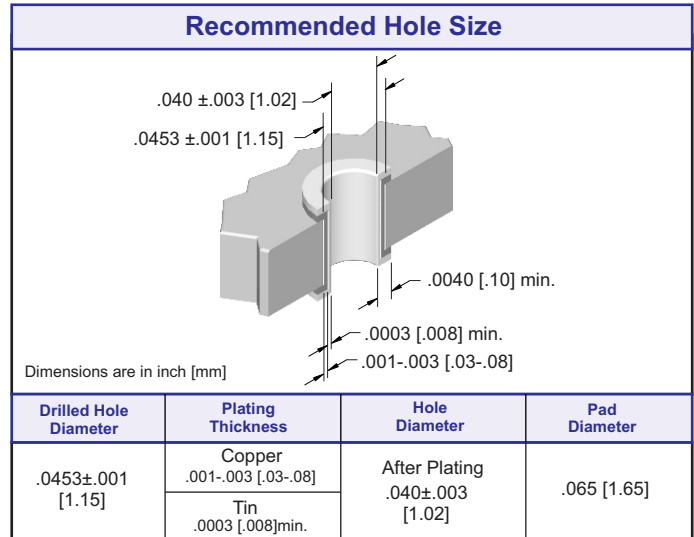

## Specifications

Insulator Material: Thermoplastic , color natural (brown)  
 94 V-O, UL Rated.  
 Contact Material: Beryllium Copper  
 Contact Plating: Gold and/or Tin over .000050" Nickel,  
 (See Contact Plating Options).  
 Current Range at +20C = 3 amp  
 Ambient Temp. Of +70C = 2 amp  
 +100C = 1 amp  
 Contact Resistance:  
 ≤ 20m Ω  
 Insulation Resistance:  
 ≥ 10<sup>12</sup> m Ω at 100 VDC  
 Dielectric Strength:  
 ≤ 1000 VDC  
 Compliant Section Insertion Force:  
 40 lbs max per contact  
 Compliant Section Withdrawal Force:  
 10 lbs min. per contact  
 Recommended Board Thickness:  
 .093"+  
 Operating Temperature:  
 -65°C to +125C



CONTACTS	A	B	C	D
100	60.96 [2.400]	64.14 [2.524]	74.93 [2.950]	82.55 [3.250]
120	73.66 [2.900]	76.81 [3.024]	87.63 [3.450]	95.25 [3.750]
128	78.74 [3.100]	81.89 [3.224]	92.71 [3.650]	100.33 [3.950]
140	86.36 [3.400]	89.51 [3.524]	100.33 [3.950]	107.95 [4.250]
160	99.06 [3.900]	102.21 [4.024]	113.03 [4.450]	120.65 [4.750]
180	111.76 [4.400]	114.91 [4.524]	125.73 [4.950]	133.35 [5.250]
200	124.46 [4.900]	127.61 [5.024]	138.43 [5.450]	146.05 [5.750]
220	137.16 [5.400]	140.31 [5.524]	151.13 [5.950]	158.75 [6.250]
240	149.86 [5.900]	153.01 [6.024]	163.83 [6.450]	171.45 [6.750]
260	162.56 [6.400]	165.71 [6.524]	176.53 [6.950]	184.15 [7.250]
280	175.26 [6.900]	178.41 [7.024]	189.23 [7.450]	196.85 [7.750]
300	187.96 [7.400]	191.11 [7.524]	201.93 [7.950]	209.55 [8.250]

## APPROVALS



Recognized under the recognized component  
 Program of Underwriters Laboratories, Inc.  
 File Numbers: E176234

## Bellcore GRE 1217 CORE

Connectors are available that meet the requirements of Bellcore GRE-1217-CORE. Please consult factory for ordering information.

# 4 ROW HDI Female Vertical Connector

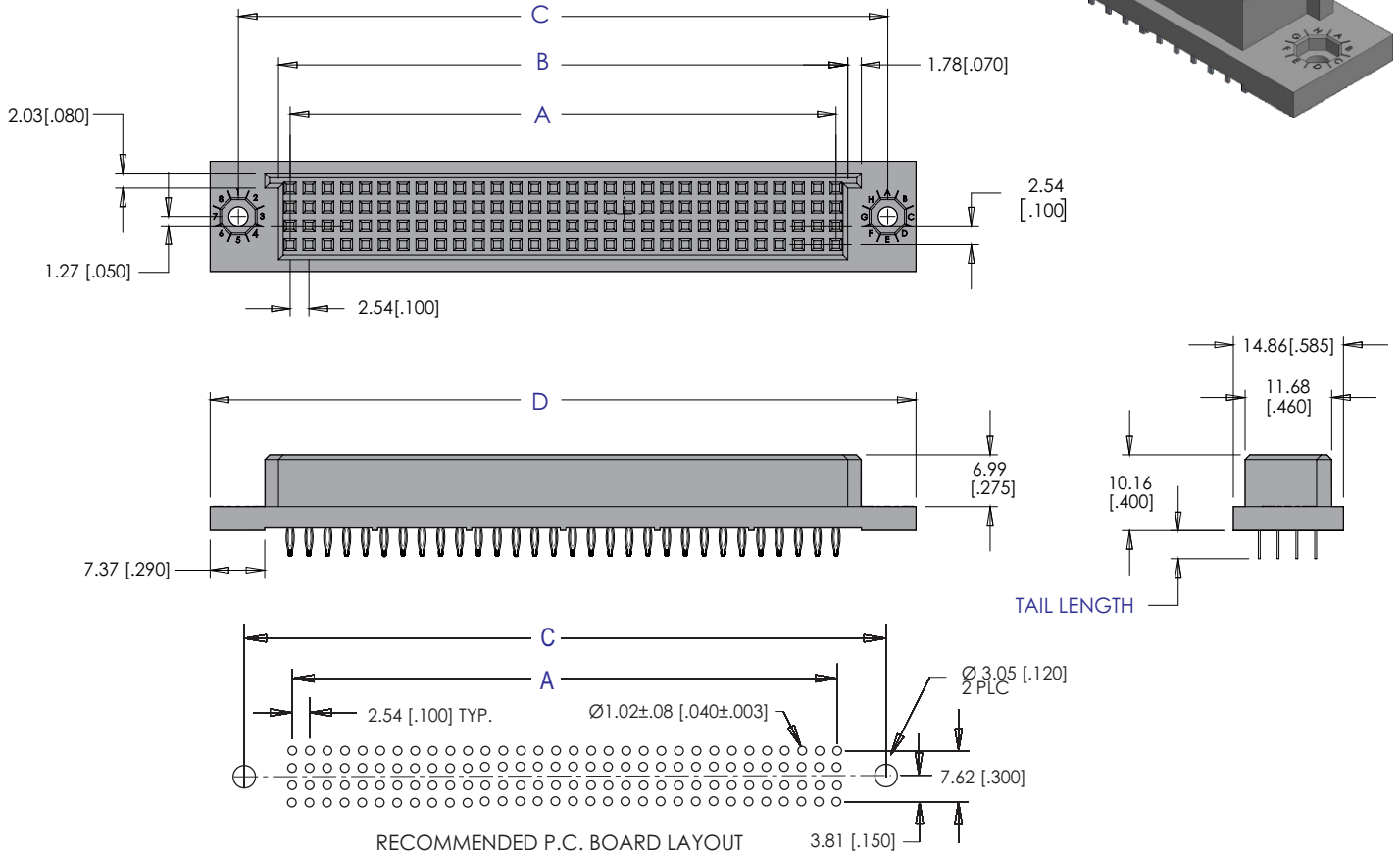
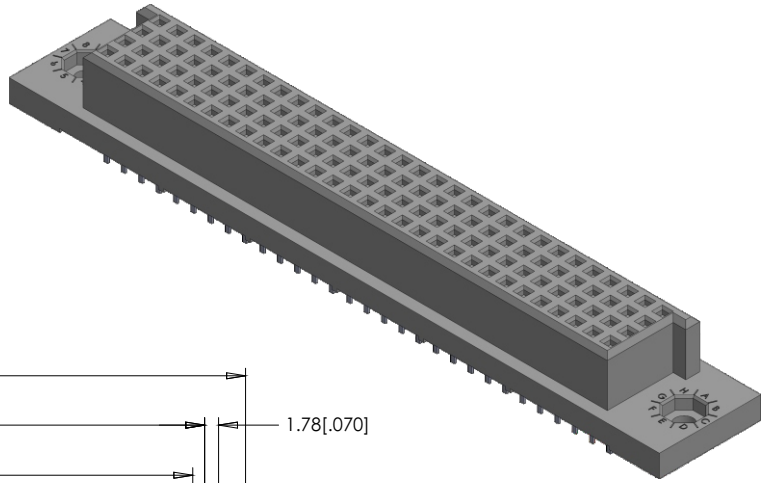

## PART NUMBERING

