

Specifications

Insulator Material: Glass filled polyester, type PBT,
94 V-O, UL Rated.
Contact Material: Phosphor Bronze Alloy
Contact Plating: Gold and/or Tin over .000050" Nickel,
(See Contact Plating Options).
Current Rating: 3 amp at 30°C
Contact Resistance: Contact to Daughter Card:
10 m Ω
Insulation Resistance: 5000 M Ω
Dielectric Withstand Voltage: 1000 V AC
Daughter Board Insertion Force:
16 oz max. per contact pair
when tested with a .071" thick gage.

Daughter Board Withdrawal Force:
1 oz min. per contact pair
when tested with a .054" thick gage.



Recognized under the recognized component
Program of Underwriters Laboratories, Inc.
File Numbers: E176234

For drawings, technical data or samples,
contact E.C.S. at (714) 750-9410

CONTACTS	A	B	C	D	E	F
4/8	.300 [7.62]	.500 [12.70]	.675 [17.15]	.975 [24.77]	1.275 [32.39]	.330 [8.38]
5/10	.400 [10.16]	.600 [15.24]	.775 [19.69]	1.075 [27.31]	1.375 [34.93]	
6/12	.500 [12.70]	.700 [17.78]	.875 [22.23]	1.175 [29.85]	1.475 [37.47]	
7/14	.600 [15.24]	.800 [20.32]	.975 [24.77]	1.275 [32.39]	1.575 [40.01]	
8/16	.700 [17.78]	.900 [22.86]	1.075 [27.31]	1.375 [34.93]	1.675 [42.55]	
10/20	.900 [22.86]	1.100 [27.94]	1.275 [32.39]	1.575 [40.01]	1.875 [47.63]	
12/24	1.100 [27.94]	1.300 [33.02]	1.475 [37.47]	1.775 [45.09]	2.075 [52.71]	
13/26	1.200 [30.48]	1.400 [35.56]	1.575 [40.01]	1.875 [47.63]	2.175 [55.25]	
15/30	1.400 [35.56]	1.600 [40.64]	1.775 [45.09]	2.075 [52.71]	2.375 [60.33]	
18/36	1.700 [43.18]	1.900 [48.26]	2.075 [52.71]	2.375 [60.33]	2.675 [67.95]	
19/38	1.800 [45.72]	2.000 [50.80]	2.175 [55.25]	2.475 [62.87]	2.775 [70.49]	
20/40	1.900 [48.26]	2.100 [53.34]	2.275 [57.79]	2.575 [65.41]	2.875 [73.03]	
22/44	2.100 [53.34]	2.300 [58.42]	2.475 [62.87]	2.775 [70.49]	3.075 [78.11]	.400 [10.16]
23/46	2.200 [55.88]	2.400 [60.96]	2.575 [65.41]	2.875 [73.03]	3.175 [80.65]	
25/50	2.400 [60.96]	2.600 [66.04]	2.775 [70.49]	3.075 [78.11]	3.375 [85.73]	
26/52	2.500 [63.50]	2.700 [68.58]	2.875 [73.03]	3.175 [80.65]	3.475 [88.27]	
28/56	2.700 [68.58]	2.900 [73.66]	3.075 [78.11]	3.375 [85.73]	3.675 [93.35]	
30/60	2.900 [73.66]	3.100 [78.74]	3.275 [83.19]	3.575 [90.81]	3.875 [98.43]	
31/62	3.000 [76.20]	3.200 [81.28]	3.375 [85.73]	3.675 [93.35]	3.975 [100.97]	
35/70	3.400 [86.36]	3.600 [91.44]	3.775 [95.89]	4.075 [103.51]	4.375 [111.13]	
36/72	3.500 [88.90]	3.700 [93.98]	3.875 [98.43]	4.175 [106.05]	4.475 [113.67]	
40/80	3.900 [99.06]	4.100 [104.14]	4.275 [108.59]	4.575 [116.21]	4.875 [123.83]	
43/86	4.200 [106.68]	4.400 [111.76]	4.575 [116.21]	4.875 [123.83]	5.175 [131.45]	
44/88	4.300 [109.22]	4.500 [114.30]	4.675 [118.75]	4.975 [126.37]	5.275 [133.99]	
49/98	4.800 [121.92]	5.000 [127.00]	5.175 [131.45]	5.475 [139.07]	5.775 [146.69]	
50/100	4.900 [124.46]	5.100 [129.54]	5.275 [133.99]	5.575 [141.61]	5.875 [149.23]	
60/120	5.900 [149.86]	6.100 [154.94]	6.275 [159.39]	6.575 [167.01]	6.875 [174.63]	

Dimensions are in inch [mm]

POLARIZING KEYS

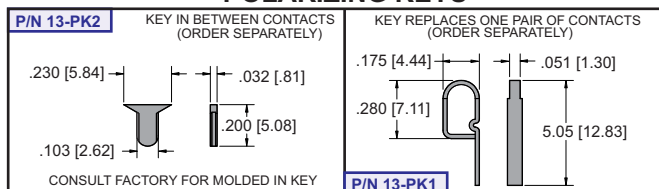

.100[2.54] Contact Centers, Low Profile Card Edge

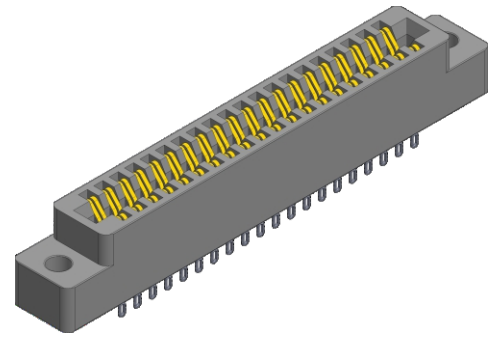
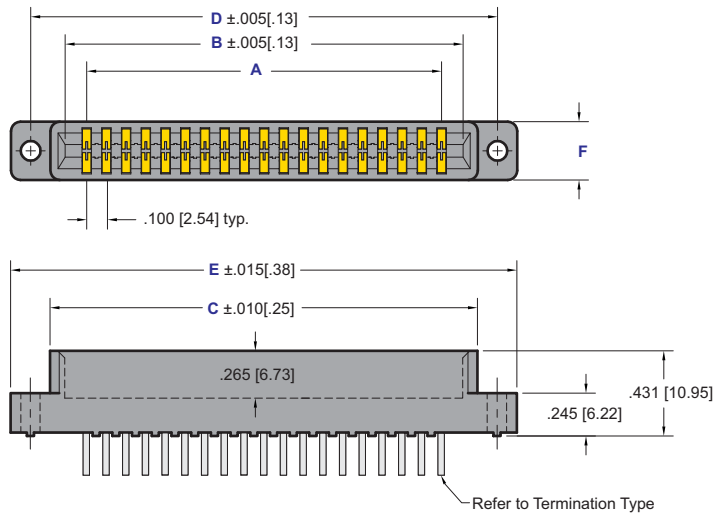

Dimensions are in inch [mm]

TERMINATION TYPE

<p>Eyelet Accepts 3-#26 AWG .225 [5.72] .007 [.18] thick Overall plated only 1 = Eyelet</p>	<p>2 = Narrow Dip Solder</p>	<p>3 = Wide Dip Solder</p>	<p>.062 [1.57] .150 [3.81] 4 = Right Angle</p>	<p>5 = V Crimp</p>
--	------------------------------	----------------------------	--	--------------------

CONTACT CENTERS

<p>1 = .100 x .140 [2.54 x 3.56]</p>	<p>2 = .100 x .200 [2.54 x 5.08]</p>	<p>.062 [1.57] .150 [3.81] 3 = .100 x .150 [2.54 x 3.81] (Right Angle Only)</p>	<p>.052±.005 4 = Card Extender option 1</p>	<p>.052±.005 5 = Card Extender option 2</p>
--------------------------------------	--------------------------------------	---	--	--

MOUNTING STYLES

<p>∅ .125 [3.18] 1 = Clearance Hole</p>	<p>#4-40 2 = Threaded Insert</p>	<p>∅ .116 [2.95] Clearance for #4-40 screw 3 = Floating Bobbin</p>	<p>Ears Removed 4 = No Mounting Ears</p>	<p>.135 [3.43] 5 = Side Mounting</p>
--	---	--	---	---

PART NUMBERING

