

2mm HDM High Speed, Male Connector



144 Contacts, Vertical, Guide Pin Option

SPECIFICATION

- Housing: liquid crystal polymer (LCP), glass-filled polymer, UL 94V-O, color black
- Contact: Copper alloy
- Plating: Contact Area: Gold over Nickel
Tail Area: Gold or Matte Tin over Nickel
- Operating Temperature: -55 to 105°C
- Operating Voltage, Sea Level: 1000 volts rms at 60 hertz
- Current: 1.0A per contact at 70° C (fully loaded).
- Contact Insertion Force: 1.6 OZ. [0.45 N] typical per contact
- Contact Withdrawal Force: 0.54 OZ. [0.15 N] min. per contact
- Insulation Resistance: 1000 Megohms min.
- Dielectric Withstanding Voltage: 1000V
- Recommended Holes Size: \varnothing 1.20 recommended pad
 \varnothing 0.80- \varnothing 0.65 plated thru hole
 \varnothing 0.838 drilled hole

THIS DRAWING SHOWN
P/N: 70B-144-0324-60-AE
FOR REFERENCE ONLY

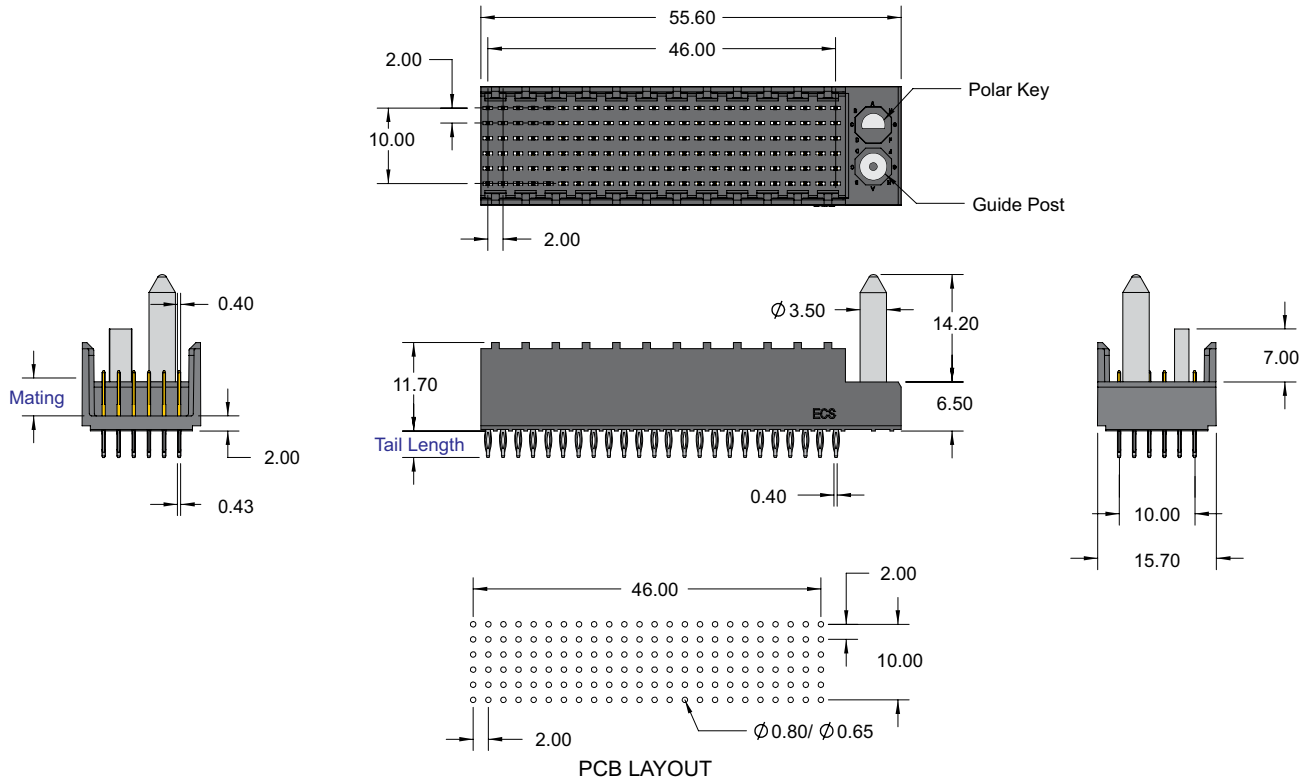

PART NUMBERING



MATING

- 1= 5.0
- 2= 5.5
- 3= 6.0

TAIL TYPE

- 1 = SOLDER
- 2 = PRESS FIT

TAIL LENGTH

- 1= 2.0 solder
- 2= 2.5 solder
- 3= 3.0 solder
- 4= 3.5 solder or press-fit

POLAR KEY POSITION

- A, B, C, D, E, F, G, H
- O = WITH OUT

GUIDE POST

- O = WITH OUT
- A = WITH

PLATING

| 50 μ m Nickel Underplate | |
|------------------------------|-----------------|
| Mating Area | Tail |
| 03 = Flash Au | Flash Au |
| 05 = Flash Au | 100 μ m Tin |
| 20 = 15 μ m Gold | 100 μ m Tin |
| 30 = 30 μ m Gold | 100 μ m Tin |
| 60 = 30 μ m Gold | Flash Au |

