

# 2mm HDM High Speed, Male Connector



## 144 Contacts, Vertical, Guide Pin Option, Stand-Off

### SPECIFICATION

- Housing: liquid crystal polymer (LCP), glass-filled polymer, UL 94V-O, color black
- Contact: Copper alloy
- Plating: Contact Area: Gold over Nickel  
Tail Area: Gold or Matte Tin over Nickel
- Operating Temperature: -55 to 105°C
- Operating Voltage, Sea Level: 1000 volts rms at 60 hertz
- Current: 1.0A per contact at 70° C (fully loaded).
- Contact Insertion Force: 1.6 OZ. [0.45 N] typical per contact
- Contact Withdrawal Force: 0.54 OZ. [0.15 N] min. per contact
- Insulation Resistance: 1000 Megohms min.
- Dielectric Withstanding Voltage. 1000V
- Recommended Holes Size: Ø1.20 recommended pad  
Ø0.80-Ø0.65 plated thru hole  
Ø0.838 drilled hole

THIS DRAWING SHOWN  
P/N: 70B-144-1124-60-AE  
FOR REFERENCE ONLY

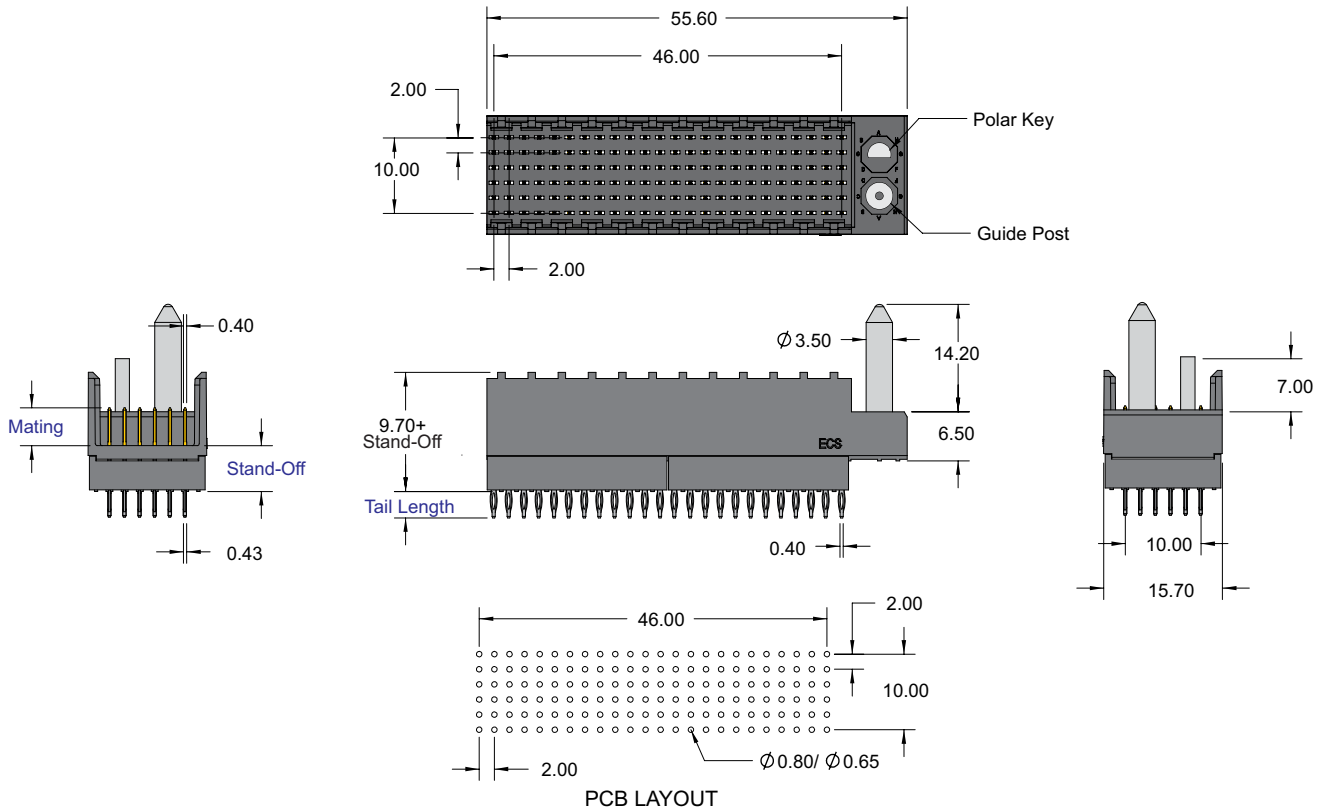

### PART NUMBERING



#### STAND-OFF

- 1= 06.05
- 2= 10.05
- 3= 15.05

#### MATING

- 1= 5.0
- 2= 5.5
- 3= 6.0

#### TAIL TYPE

- 1 = SOLDER
- 2 = PRESS FIT

#### TAIL LENGTH

- 1= 2.0 solder
- 2= 2.5 solder
- 3= 3.0 solder
- 4= 3.5 solder or press-fit

#### POLAR KEY POSITION

- A, B, C, D, E, F, G, H
- O= WITH OUT

#### GUIDE POST

- O = WITH OUT
- A = WITH

#### PLATING

- 50µ" Nickel Underplate
- | Mating Area    | Tail      |
|----------------|-----------|
| 03 = Flash Au  | Flash Au  |
| 05 = Flash Au  | 100µ" Tin |
| 20 = 15µ" Gold | 100µ" Tin |
| 30 = 30µ" Gold | 100µ" Tin |
| 60 = 30µ" Gold | Flash Au  |

