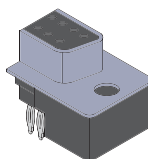
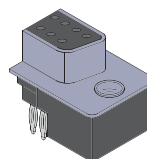
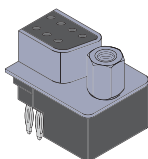
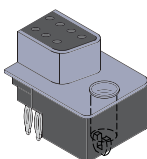
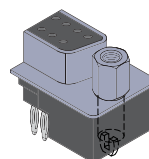
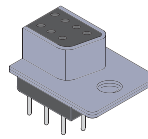
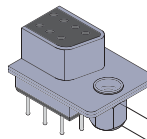
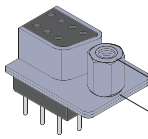
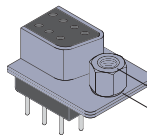
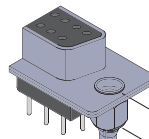
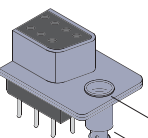
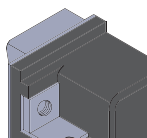
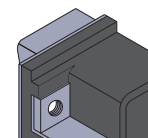
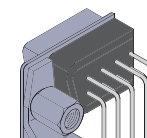
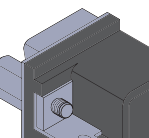
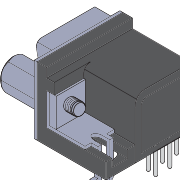
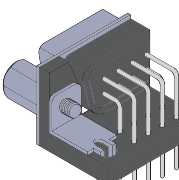
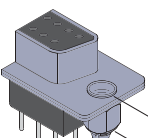
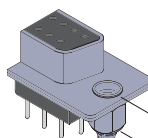

## Press-Fit and Plastic Body Connectors

<p>00 = .120 dia. Thru Holes</p> 	<p>02 = #4-40 Threaded Insert</p> 	<p>03 = #4-40 Threaded Insert with #4-40 Screw Lock</p> 	<p>15 = #4-40 Threaded Insert with Board Lock</p> 	<p>16 = #4-40 Screw Lock with Board Lock</p> 
--	---	---	--	--

## Solder, Right Angle, and High Density Connectors

<p>01 = .120 dia. Riveted Front and Rear Shell</p> 	<p>04 = Riveted #4-40 UNC Open Nuts on Rear Shell</p>  <p>.158 [4.0]</p>	<p>05 = Riveted #4-40 UNC Closed Nuts on Front Shell</p>  <p>.228 [5.8]</p>	<p>06 = Riveted #4-40 UNC Open Nuts on Front Shell</p>  <p>.158 [4.0]</p>	<p>07 = Riveted #4-40 UNC Close Ground Stand-Off on Rear Shell (Stamped Contact)</p>  <p>.276 [7.0]</p>
<p>07 = Riveted #4-40 UNC Close Ground Stand-Off on Rear Shell (Machined Contact)</p>  <p>.276 [7.0]</p>	<p>08 = Riveted Ground Hooks with #4-40 UNC Open</p> 	<p>09 = Riveted Ground Tabs with #4-40 UNC Open (Stamped Contact)</p> 	<p>09 = Riveted Ground Tabs with #4-40 UNC Open (Machined Contact)</p> 	<p>10 = Riveted Ground Hooks Pre-Loaded #4-40 UNC Hex Screws</p> 
<p>11 = Assembly Ground Hooks By #4-40 UNC Hex Screws (Stamped Contact)</p> 	<p>11 = Assembly Ground Hooks By #4-40 UNC Hex Screws (Machined Contact)</p> 	<p>12 = Riveted #4-40 UNC Close Ground Stand-Off on Rear Shell (Stamped Contact) for High Profile Connectors</p>  <p>.425 [10.8]</p>	<p>13 = Riveted #4-40 UNC Close Ground Stand-Off on Rear Shell (Stamped Contact)</p>  <p>.354 [8.99]</p>	<p>CONSULT FACTORY FOR OTHER MOUNTING STYLE OPTIONS</p>