



# 9600S Series Sockets

## .050 x.100 SMT Socket Dual Entry

### Specifications

Insulator Material: Glass filled polyester, Thermoplastic,  
 94V-O Nylon-6T, UL Recognized.  
 Contact Material: Phosphor Bronze  
 Contact Plating: Gold and/or Tin over .000050" Ni,  
 (See contact plating options)  
 Insulation Resistance: 5000 M ohms min.  
 Contact Resistance: 20 m ohms max.  
 Dielectric Withstand Voltage: 500 VAC  
 Current Rating: 1 AMP  
 Operating Temperature: -40°C To +105°C  
 Max. Processing Temp.: 230°C for 60 seconds  
 UL File Numbers: E146967 & E176234

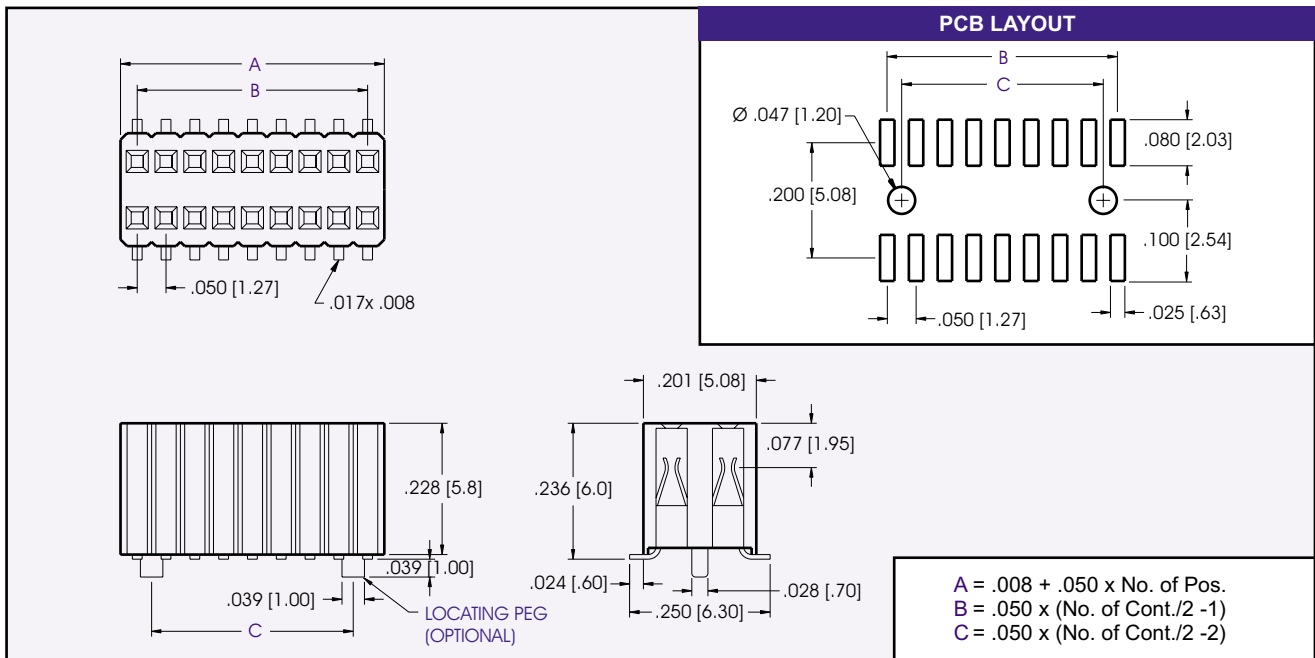
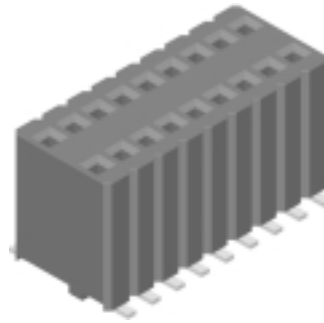

ALL DIMENSIONS ARE IN INCHES [MM]

### PART NUMBERING

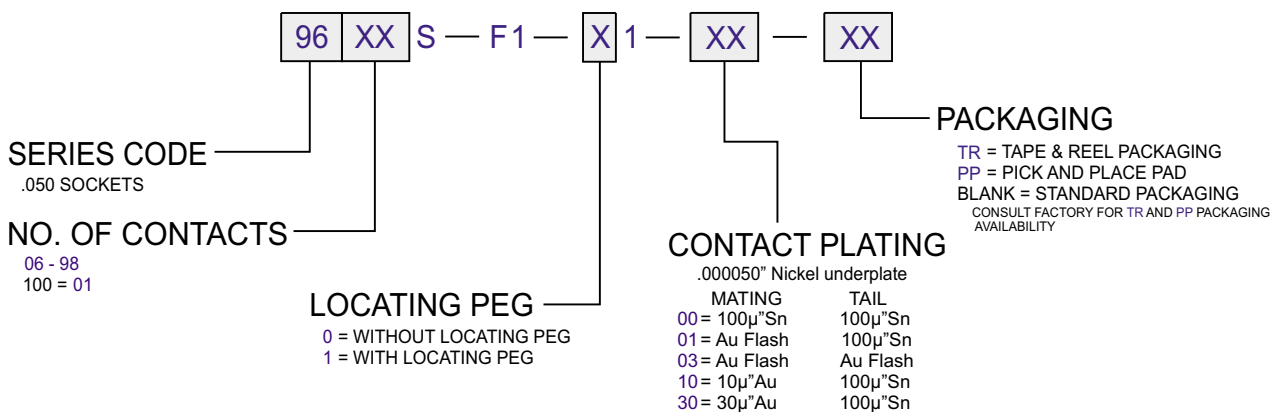

CONSULT FACTORY FOR CUSTOM CONNECTORS BUILT TO YOUR SPECIFICATION